

Hanson Snow Blower

**Two-Stage Snow Blower
For 4WD Pick Up Trucks**

Operator's Manual



**Distributed by:
Hanson Products Co.
2141 North Central Avenue
Rockford, Illinois 61101
Phone: (815)316-1096
Fax: (815)316-1142
Hansonsnowblowers.com**

Important Operation Detail:

To Operate:

For cold weather operation, below 45° F (7° C), move the slide lever on the air cleaner base towards the blower housing (closed position). For temperatures above 45° F (7° C), the slide must be moved towards the rear of the blower (open position). Failure to do so may result in poor operation, internal engine damage, and/or non compliant exhaust emission levels.

NOTE: These instructions should be retained by the end user for referral when seasonal conversion is necessary.

Take note! This safety alert symbol, found throughout this manual is used to call your attention to instructions involving your personal safety and the safety of others. Failure to follow these instructions can result in injury or death.



**These symbols mean Attention, Become Alert,
Your safety is involved!**

Signal Words: Note the use of the signal words **Danger**, **Warning** and **Caution** with the safety messages. The appropriate signal word for each has been selected using the following guidelines:

Danger: Indicates an imminently hazardous situation that, if not avoided, will result in death or serious injury. This signal word is to be limited to the most extreme situations typically for machine components, which, for functional purposes, cannot be guarded.

Warning: Indicates a potentially hazardous situation that, if not avoided, could result in death or serious injury, and includes hazards that are exposed when guards are removed. It may also be used to alert against unsafe practices.

Caution: Indicates a potentially hazardous situation that, if not avoided, may result in minor or moderate injury. It may also be used to alert against unsafe practices.

If you have any questions not answered in this manual or require additional copies or the manual is damaged, please contact your dealer or

Hanson Products Co.
2141 North Central Avenue
Rockford, Illinois 61101
Phone: (815)316-1096
Fax: (815)316-1142
Hansonsnowblowers.com

General Information

PRE-OPERATION INSPECTION

Check fuel levels and refuel when equipment is cold. This will also avoid inconvenience later. Attach the Snow Blower to your vehicle in accordance with the instructions for INSTALLATION. Check oil Lubricant levels.



WARNING: Inspect all bolted connections and attachments to be sure that they are properly tightened. Failure to do so may result in personal injury or death. Skids on each side of the main body must be lowered to eliminate rocks or any other debris from entering impeller assembly.



WARNING: Thoroughly inspect the area where the equipment is to be used and remove all debris, boards, wire, steel and other foreign objects. Failure to heed may result in personal injury or death.

SNOWBLOWER CONTROLS



WARNING: Maintain all safety devices (such as emergency shut-off switches) in working order. Failure to do so may result injury or death.

Your unit has electric controls installed for controlling the rotation of the Discharge Chute and vertical adjustment of the Chute Deflector. You can make these adjustments “on the go” by actuating the Toggle Switch which regulates that adjustment.

SNOW REMOVAL PROCEDURES



WARNING: Direct snow to open areas only. Never direct discharge at bystanders, vehicles or buildings. Failure to heed may result in personal injury or death.



WARNING: Keep windows clear to provide good visibility. Failure to heed may result in personal injury or death. Do not try to direct snow discharge upwind. Always set discharge downwind.



DANGER: Auger can crush or dismember. Keep well clear and keep others away when unit is running. Failure to heed may result in personal injury or death.



DANGER: Keep hands out of discharge chute and impeller when unit is running. Failure to heed may result in personal injury or death.



DANGER: Shut off Power Supply Engine before unclogging, adjusting or servicing unit. Never attempt to service or approach the snow blower when it is running. For hydraulic driven units, relieve all pressure by opening control valve after power supply engine has been stopped before unclogging, adjusting or servicing unit. Failure to heed may result in injury or death.

SNOW REMOVAL PROCEDURES, continued

Snow removal should be done before excessive snow accumulation results. If snow is removed promptly less power will be required, the job will be easier and quicker, and the strain to the equipment will be reduced.

Snow left sitting picks up moisture, becomes heavier and more difficult to handle and may freeze together in a mass.

Be prepared for the job. If your tractor or vehicle will require chains for traction, install them.

Your Snow Blower provides for turning of the Discharge Chute to direct snow either left or right and the Chute Deflector can be adjusted up or down for best operation. Standard controls are manual. Optional electric controls are available for added convenience.

Some things you should know if the snow blower becomes clogged:

It is anticipated that at some time it may be necessary for you to clean out or unclog your snow blower. You must practice some safety procedures to accomplish this and some reasons that may not be readily obvious are presented. It just makes good sense that you should not attempt any kind of service with the Power Source Engine running. Furthermore it is possible that when plugged there may be strain on the impeller, auger or drive shaft. This is particularly true if a jam-up or clog has been caused from pinching or catching a foreign object in the mechanism. This pressure or strain must be eliminated by disengagement of the clutch to the snow blower. If the unit is hydraulically driven, relieve pressure by shutting off the Power Supply Engine and then opening the control valve to release stored energy. If this is not done, you may be in danger of receiving serious injury from any of these parts suddenly moving when the obstruction is removed.

ENGINE STARTING AND OPERATING INSTRUCTIONS

Important! For proper break-in on your new engine, allow it to idle for 15 minutes the first time it is started. This is only recommended for the first running period.

The throttle switch is solenoid activated and it controls low speed and high speed RPM settings.

Always start the engine in low speed RPM setting.

As soon as engine is warmed up, push toggle switch to high speed RPM setting.

Never blow snow in low speed RPM setting as damage to solenoid may occur.

Be sure to turn the start key off when snow blower is not in use.



SAFETY...YOU CAN LIVE WITH IT

EQUIPMENT SAFETY GUIDELINES

Safety of the operator is one of the main concerns in designing and developing a new piece of equipment. Designers and manufacturers build in as many safety features as possible. However, every year many accidents occur which could have been avoided by a few seconds of thought and a more careful approach to handling equipment. You, the operator, can avoid many accidents by observing the following precautions in this section. To avoid personal injury, study the following precautions and insist those working with you, or for you, follow them.

In order to provide a better view, certain photographs or illustrations in this manual may show an assembly with a safety shield removed. However, equipment should never be operated in this condition. Keep all shields in place. If shield removal becomes necessary for repairs, replace the shield prior to use.

Replace any CAUTION, WARNING, DANGER or instruction safety decal that is not readable or is missing. Location of such decals is indicated in this booklet.

Do not attempt to operate this equipment under the influence of drugs or alcohol.

Review the safety instructions with all users annually.

This equipment is dangerous to children and persons unfamiliar with its operation. The operator should be a responsible adult familiar with machinery and trained in this equipment's operations. Do not allow persons to operate or assemble this unit until they have read this manual and have developed a thorough understanding of the safety precautions and of how it works.

To prevent injury or death, do not paint over, remove or deface any safety signs or warning decals on your equipment. Observe all safety signs and practice the instructions on them.

Never exceed the limits of machinery. If its ability to do a job, or to do so safely, is in question – Do not try it.



DANGER

Augers can crush or dismember. Keep well clear and keep others away when unit is running. Keep hands out of discharge chute and impeller when unit is running. Shut off power supply engine and disengage clutch before unclogging, adjusting or servicing unit. For hydraulic driven units, relieve all hydraulic pressure by opening control valve after power supply engine has been stopped before unclogging, adjusting or servicing unit. Keep all shields, guards and covers in place.



WARNING

Know how to stop all equipment operation in case of emergency. Direct snow to open areas only. Never direct discharge at bystanders, vehicles or buildings, foreign objects or ice chunks in snow may be thrown much further than expected. Do not operate when blowing snow restricts visibility. Keep people away from machine and discharge area. Never allow anyone in front of unit. Stop Power Supply Engine before leaving the operator's seat. Thoroughly inspect the area where the equipment is to be used and remove all debris, boards, wire, steel and other foreign objects.

For your safety you must not operate, service, inspect or otherwise handle this equipment unless you have read the Owner's Manual and have been properly trained in its intended usage.
Keep hands, feet and clothing away from power driven parts in motion.
Never make adjustments or lubricate the machine while it is in motion.
Never allow children to operate this equipment.
Do not operate on terrain that is so steep that rollover could occur.
Make sure that your vehicle has adequate ballast for stability.
See your vehicle Owner's Manual.
Use adequate safety warning lights and devices as required by local regulations.
Require anyone who will operate this machine to read and understand the "Operator's Manual."
Give necessary instructions.
Be sure this "Operator's Manual" is made available to them and that they have been instructed in safe operating procedures.

Failure to heed may result in personal injury or death

Additional copies are available from the manufacturer.

Safety Sign Decals on All Units

The types of Safety Signs on the equipment are shown in the illustrations following. Good safety requires that you familiarize yourself with the various Safety Signs, the type of warning and the area, or particular function related to that area that requires your safety awareness.



These warning stickers must be always displayed on your snow blower. If they are missing or not readable, contact the factory for replacements.

Safety Sign Decals, continued



If Safety Sign decals have been damaged, removed, become illegible or parts have been replaced without decals, new decals must be applied. New decals are available from your authorized distributor or factory.



Remember: Your best assurance against accidents is a careful and responsible operator. If there is any portion of this manual or function you do not understand, contact your local authorized dealer or the manufacturer.



Before operating:

Carefully study and understand this manual.

Do not wear loose fitting clothing, which may catch in moving parts.

Always wear protective clothing and substantial shoes.

It is recommended that suitable protective hearing and (eye protection) sight protectors be worn.

Be sure that there are no tools lying on or in the equipment.

Do not use the unit until you are sure that the area is clear, especially children and animals.

Don't hurry the learning process or take the unit for granted.

Ease into it and become familiar with your new equipment.

Practice operation of your equipment and its attachments.

Completely familiarize yourself and other operators with its operation before using.

Be especially observant of the operated area and terrain- watch for holes, rocks or other hidden hazards.

Always inspect the area prior to operation.

Do not operate near the edge of drop-offs of banks.

Do not operate on steep slopes as overturn may result.

Operate up and down (not across) intermediate slopes.

Avoid sudden starts and stops

Pick the most level possible route when transporting across terrain.

Avoid the edges of ditches or gullies and steep hillsides.

Be extra careful when working on inclines.

Do not walk or work under raised components or attachments unless securely positioned and blocked.

Keep all bystanders, pets and livestock clear of the work area.

Never stand alongside of unit with engine running or attempt to start engine and/or operate machine while standing alongside of unit.

Never leave running equipment attachments unattended.



DANGER

Never operate the snow blower without proper guards in place. Make inspection and repairs before starting.

Do not place hands or feet near or under rotating parts. Keep clear of discharge opening at all times.

Keep children and pets away from area where unit is being used.

Do not direct discharge at bystanders, windows or automobiles. Do not allow anyone in front of unit.

Stop the engine whenever you leave the operating position. Before unclogging the collector, impeller or discharge chute, make sure all moving parts have stopped.

When cleaning, repairing, inspecting or storing, disengage the power takeoff, lower the attachment, set the parking brake, stop the engine and remove the key.

Wiring instructions

All machines have 2 RV plugs –the larger one is for engine functions; the smaller one is for chute and deflector control.

1. Drill 1-3/8" hole in firewall of truck (usually just right of center)
2. With control box in cab, pass connector cable through hole toward front of truck. (White connector.)
3. Pass the 4-wire connector to the front of the truck. (White connector.)
4. The large welding cable (#4 wire) terminal fastens to the positive battery terminal or the positive side of the plow lift solenoid.
5. Take the 9 wire connector and plug it into the female connector. (white) and take the 4 wire connector and plug it into the female end (white). After plugging in white connectors, tape securely with electrical tape and tie off where needed
6. Fasten female connectors to corresponding male connectors for engine starting (#4 cable) and other engine functions (start, choke, and throttle advance) 9 wire connector.
7. Fasten leads to super winch for chute rotation.
8. Making sure that power is through to all functions, add at least two gallons of good gasoline to the fuel tank.
9. Make sure that people are clear of the snow blower. Never start or run the snow blower with people within 50 feet.
10. Using one hand for the key start and the other for the choke button, turn the key to start and depress the choke button until the engine starts. Depress the choke button until the engine smooths out. After several minutes of warm-up you may flip the throttle switch to high. (RPMs = 2500 @ Low; 3600 @ High) *Important! For proper break-in on your new engine, allow it to idle for 15 minutes the first time it is started.*

Fuel tank placement

Fuel tank should be located in rear of truck. Use fuel line, clamps, squeeze bulb, fittings etc. to supply fuel to engine fuel line coupler located at base of engine mounting plate.

**Fittings are interchangeable OMC Products.

Shear bolt location and replacement

Your snow blower has three shear bolts. One on the front of the fan, and one on each auger, near the gear box. They are standard ¼ x 1" grade 5 bolts.

Wire Diagram - Kohler Engine

Green to Connector
Blue to Connector

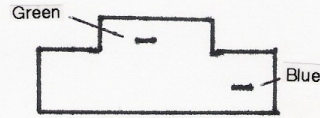

Connect to Female on Engine

Longer Black Wire
Connects to positive
Terminal of Starter



On Top of Engine:

- Brown wire to connect to the choke
- Red wire to connect to the throttle
- Green wire already connects the throttle to the choke and the ground to the engine
- Case ground to bottom screw on the engine block. (Hole already existing.) The yellow and the white go together.

Red: 4awg to starter (positive)
Black: 6awg ground to battery (negative)

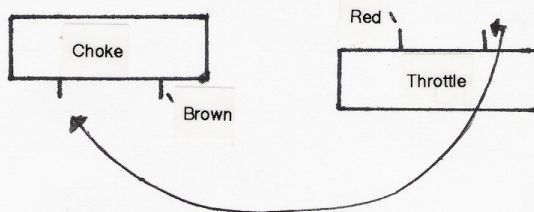

Attaching to your snow plow mount

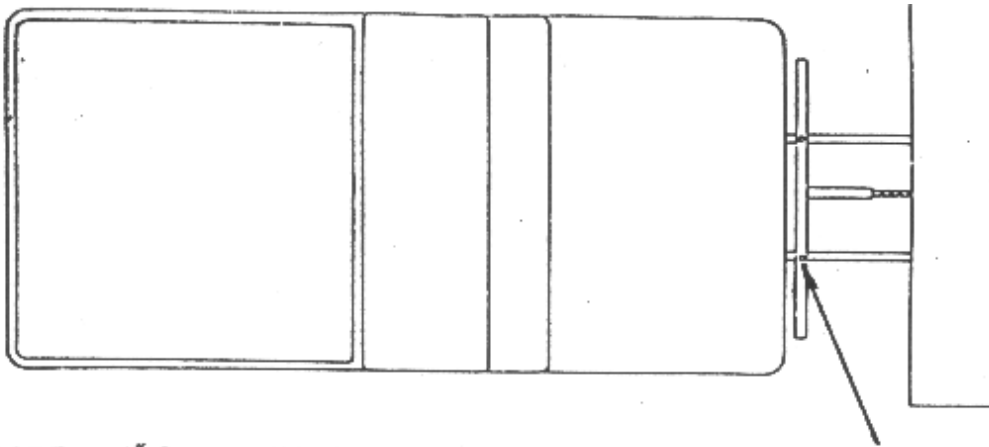

FASTEN 14" CHAIN TO BOLT THAT HOLDS THE LIGHT BRACKET IF YOU HAVE A WESTERN PLOW SET UP. FOR A MEYERS PLOW SET UP YOU WILL HAVE TO DRILL A HOLE.

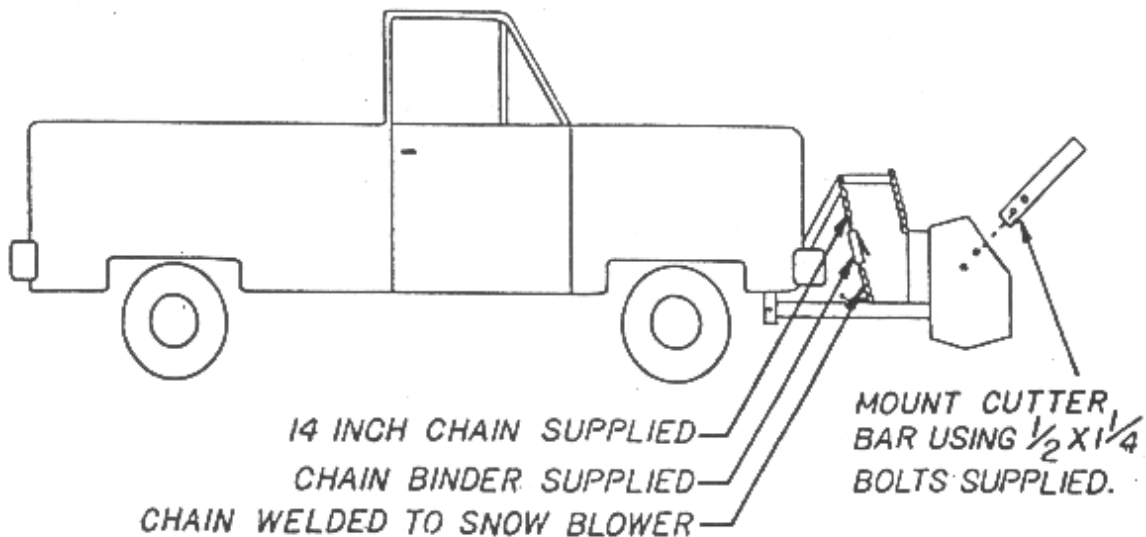

WHEN IN TRANSIT ALWAYS LOCK YOUR SNOW BLOWER IN THE RAISED POSITION USING CHAIN AND BINDER SUPPLIED. AFTER THE BLOWER HAS BEEN LOCKED IN THE RAISED POSITION, LOWER THE HYD. MECHANISM ON THE TRUCK TO TAKE THE WEIGHT OFF THE HYD. CYLINDER.

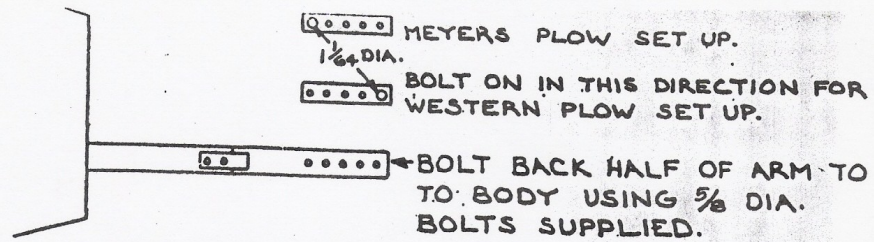

TO MAKE LIFTING OPERATION AS EASY AS POSSIBLE ON YOUR TRUCK, MOUNT SNOWBLOWER AS CLOSE TO TRUCK AS YOU CAN, YET ALLOWING CLEARANCE BETWEEN TRUCK AND SNOWBLOWER ENGINE WHEN SNOWBLOWER IS IN RAISED POSITION. TO ADJUST CLEARANCE USE MOUNTING ARM AS SHOWN.

LOCATION OF MOUNTING ARM AND SPACERS

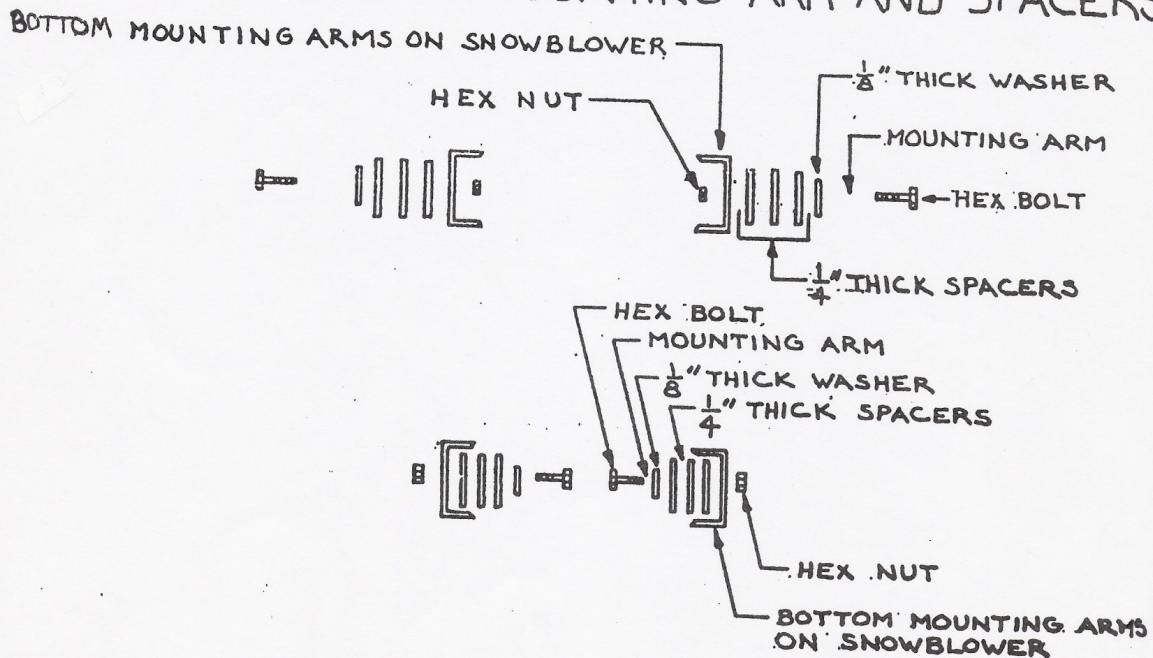

LOCATE SPACERS ON INSIDE OR OUTSIDE DEPENDING ON YOUR TRUCK SET UP. USE AS MANY SPACERS AS NEEDED, BUT MAKE SURE YOU HAVE SAME AMOUNT ON EACH SIDE.

Attaching to your snow plow mount

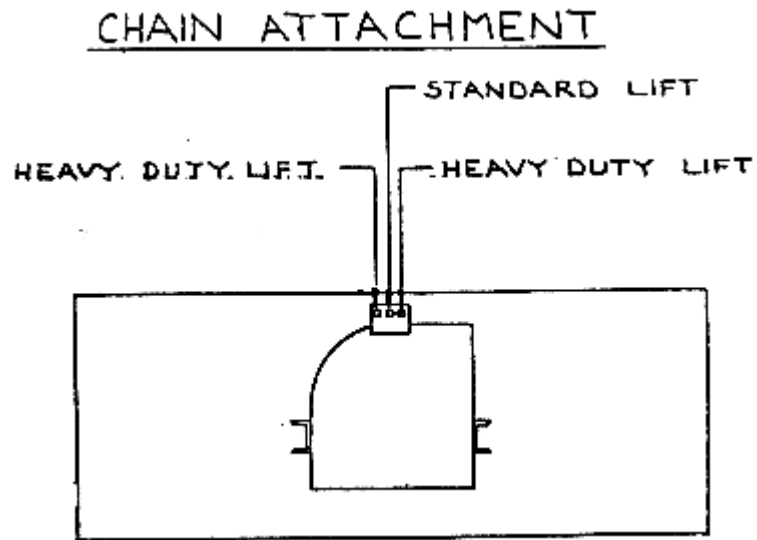

If your truck has standard lift kit, attach one chain center of plate. If you have a heavy-duty lift, attach two chains, one in each outside hole in plate.

To make lifting operation as easy as possible on your truck, mount snow blower as close to truck as you can, yet allowing clearance between truck and snow blower engine when snow blower is in raised position. To adjust clearance use mounting arm as shown.

Locate spacers: On inside or outside depending on your truck set up. Use as many spacers as needed, but make sure you have same amount on each side.

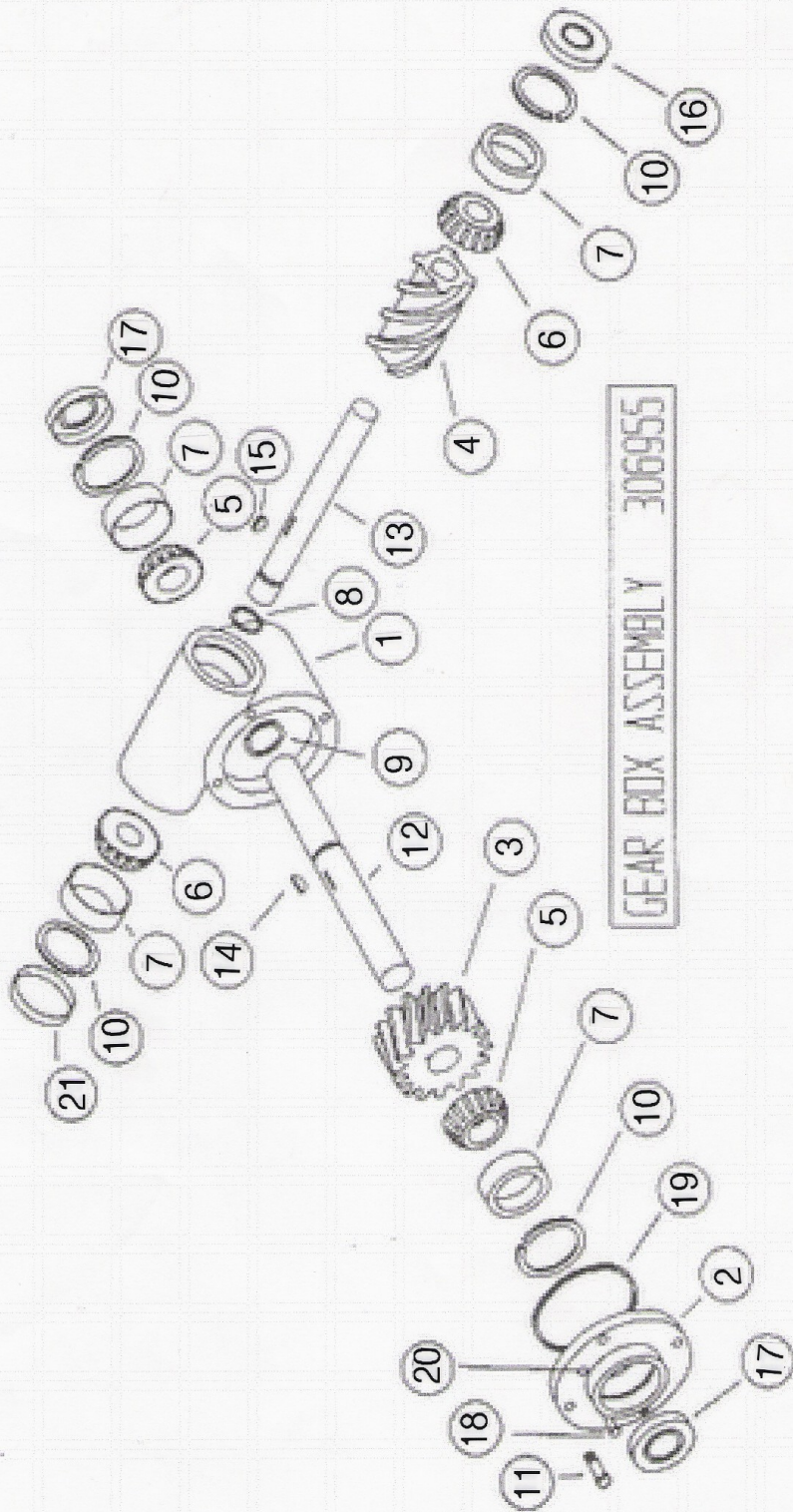

Gear Box Assembly and Parts

No.	Part No.	Qty.	Name of Part
1	A24-10	1	Housing
2	A23-2	1	Cover
3	B29-A24	1	Worm gear
4	B31-24	1	Worm
5	C10	2	Brg. Cone
6	C12	2	Brg. Cone
7	C13	4	Brg. Cup
8	D10	1	Snpring
9	D12	1	Snpring
10	D24	4	Snpring
11	D50	4	Capscrew
12	E5046	1	Shaft-output
13	E5047-H	1	Shaft-input
14	J15	1	Woodruff-key
15	J56	1	Woodruff-key
16	K10	1	Seal
17	K15	2	Seal
18	K34	1	Plug-level
19	K45	1	Gasket
20	K151	1	Plug-vent
21	K154	1	Cap
22	P17	A/R	Shim
23	K43	2	Zerk

21133A

GREASE ZERKS FOR AUGER BEARINGS ARE LOCATED ON BEARING HOUSING WITH ONE SIDE BEING ON THE TOP SIDE OF BEARING AND THE OTHER SIDE ON THE BOTTOM SIDE.

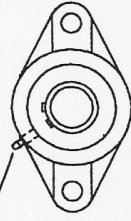

SET SCREWS (2) PER BEARING

OUTPUT SHAFT BEARINGS

GREASE ZERK FITTINGS

OUTPUT SHAFT

INPUT SHAFT (FAN SHAFT)

GEAR REDUCER

UPPER PLUG

CENTER PLUG

BREATHER VENT

DRAIN PLUG

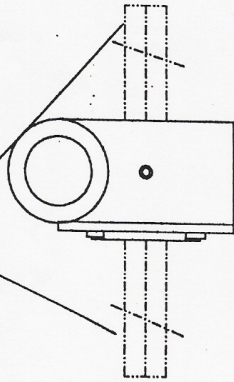

GEAR OIL 85W-140

TO CHANGE OIL, PUT SMALL PAN UNDER DRAIN PLUG AND REMOVE IT, THEN REMOVE UPPER PLUG SO OIL WILL DRAIN (THIS IS ALSO THE FILL HOLE). REPLACE DRAIN PLUG, AND REMOVE CENTER PLUG. ADD OIL THROUGH UPPER PLUG HOLE UNTIL OIL RUNS OUT OF CENTER PLUG HOLE. REPLACE THE PLUGS.

HANSON PRODUCTS INC.

GEARBOX MAINT. PORTS

Some General Tips on Blowing Snow

1. Pick an open area and rotate the discharge chute so that the snow is blown down wind.
2. Blow snow before you have excessive accumulation. Keeping the amount of snow to be removed under 12" will make the task much easier! Additionally, snow picks up moisture as it lies on the ground reducing greatly the distance it can be blown!
3. To clear a single lane, blow the snow down wind. Be sure to do the side of the road from which the wind is coming first. (See illustration 1)
4. To clear a double lane, make a pass up the center first carefully keeping auger slightly above the possible crown in the road. (See illustration 2)
5. When clearing an open area always try to blow the snow downwind. Start at the side and work your way across carefully watching out for hidden obstructions i.e. Curbs, etc. (See illustration 3)
6. Working in drifts presents the greatest challenge to the operator. Before moving into the snow, raise the blower and slowly move into the upper section of the drift. Next, back up and after lowering the blower move into the snow and take a second cut. (See illustration 4)

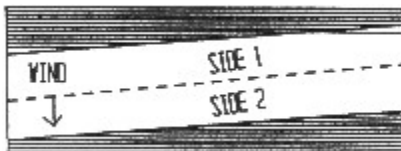

1. Clearing a single lane

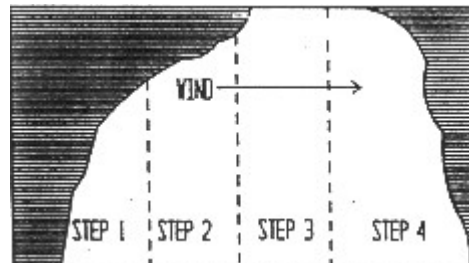

3. Clearing an open area



2. Clearing a double lane

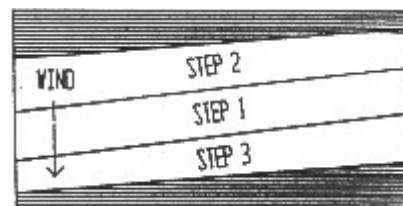

4. Deep snow

Limited Warranty

Hanson Products equipment is warranted to be free from defects in material and workmanship under normal use and service for a period of one (1) year from the date of the original purchase date, as determined by our records. To be eligible for warranty, Hanson Products equipment must be registered with us, installed and used in accordance with the recommendations of Hanson Products as found in the operator's manual. This warranty may not be amended, extended or otherwise altered by any dealer or agent of Hanson Products, and only applies to the original owner. The user shall determine the suitability of the equipment for his intended use, and assume all risks and liability in connection therewith. This limited warranty is extended only to the original purchaser from a dealer, and shall not extend to any other person or entity.

Some states/jurisdictions do not allow limitation on how long an implied warranty lasts, so the above limitation may not apply to you.

Warranty Limitations: This limited warranty will be void for any of the following reasons:

1. If the equipment is improperly used, tampers with or modified in any way, so as to affect the performance or integrity of it.
2. If the equipment is not installed according to Hanson Products' installation instructions, and in accordance with local codes.
3. If a warranty registration card is not completed and returned to Hanson Products within 20 days from the original purchase date.

Third Party Product Warranty: Warranties on third party products, such as gas engines, and hydraulic and electrical components are limited to those offered by the respective manufacturer.

Customer Remedies: In the event that Hanson Products equipment is thought to be defective, Hanson Products must be contacted immediately. Hanson Products will then determine whether the equipment should be returned to the factory, or whether an authorized dealer will make replacement and or repair in the field. All shipments to Hanson Products must be on a freight-prepaid basis, and prior written authorization must be obtained from Hanson Products for any returned items. Any equipment that has been returned and is deemed to be defective by Hanson Products will be either repaired or replaced at the discretion of Hanson Products if the equipment is still under warranty. Warranted equipment will be returned freight prepaid.

Disclaimer of Warranties and Allocation of Liability: Non implied warranty of any kind or nature, including but not limited to an implied warranty of merchantability and fitness for a particular purpose is given hereunder. Any and all warranty rights of purchase, expressed or implied, are contained in this limited warranty.

No express warranty, or any kind or nature, either oral or written, is given on the product other than the warranty set forth in this limited warranty. This limited warranty is in lieu of such other expressed or implied warranties.

In no event will Hanson Product Co., Inc. be liable for lost profits or any incidental or consequential damages.

Some states/jurisdictions do not allow the exclusion or limitation of incidental or consequential damages, so the above limitation or exclusion may not apply to you. This warranty gives you specific legal rights, and you may also have other rights, which vary from state/jurisdiction to state/jurisdiction.

Hanson Products reserves the right to make changes in the design, or to add improvements without incurring an obligation on previous goods.

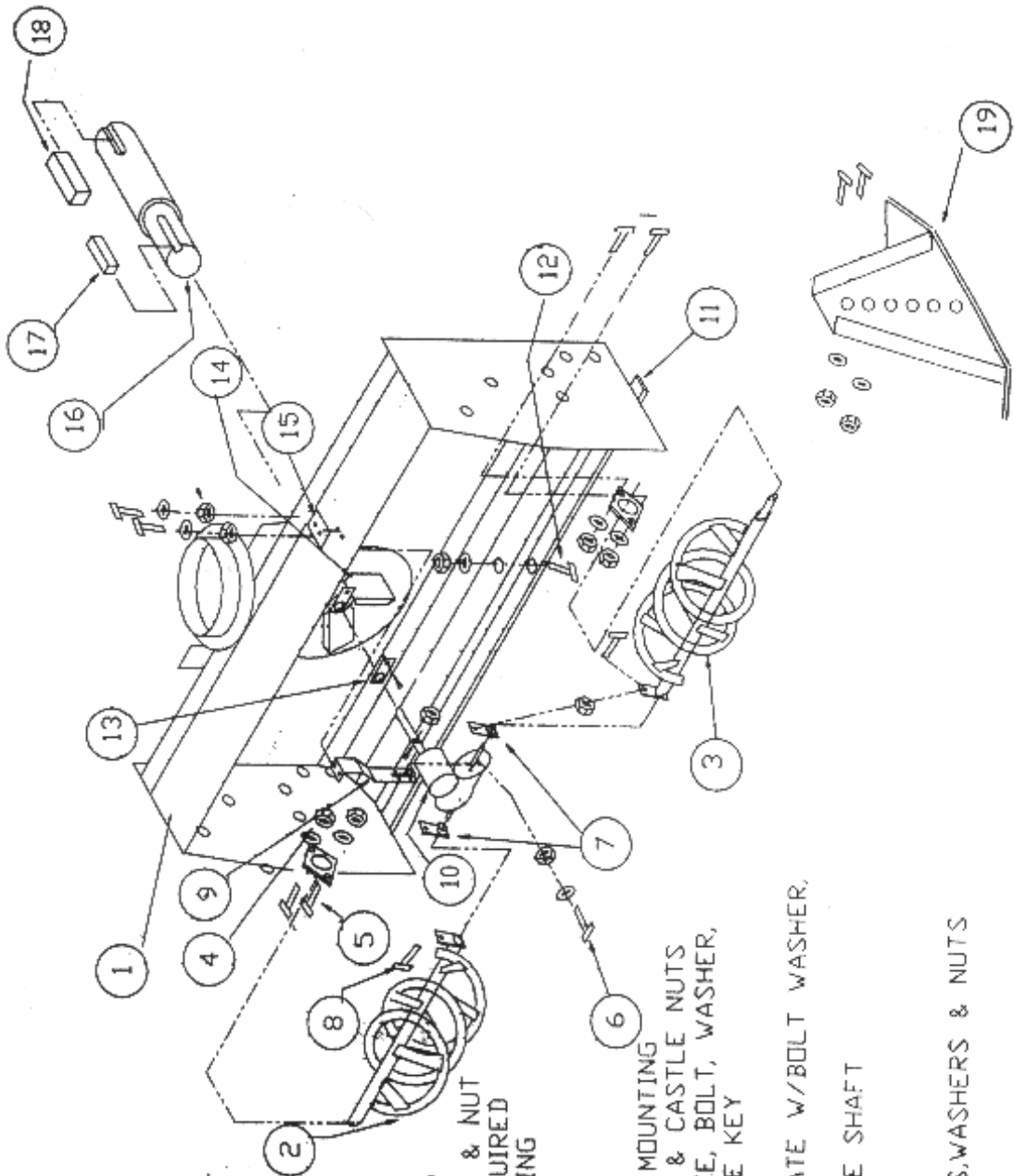

- 1...BODY
- 2...RH AUGER
- 3...LH AUGER
- 4...AUGER BEARING
- 5...1/2" BRNG MOUNT. BOLTS, NUTS, WASHERS
- 6...SHEAR PLATE MOUNTING, BOLT, WASHER, NUT (2)SETS
- 7...SHEAR PLATES(2)
- 8...1/4" SHEAR BOLT & NUT (3) GRADE 5 REQUIRED
- 9...GEAR BOX MOUNTING PLATE
- 10...GEAR DRIVE
- 11...SCRAPER BLADE
- 12...SCRAPER BLADE MOUNTING BOLTS, WASHERS, & CASTLE NUTS
- 13...FAN SHEAR PLATE, BOLT, WASHER, NUTS, AND SQUARE KEY
- 14...FAN
- 15...REINFORCING PLATE W/BOLT WASHER, AND NUT
- 16...FAN/AUGER DRIVE SHAFT
- 17...1/4" KEY
- 18...3/8" KEY
- 19...SKID SHOE/BOLTS,WASHERS & NUTS

21. Drive Belt Pulley (Auger side)
 22. Carrier Bearings

1. Engine Cover

2. Motor

3. Deflector

4. Deflector Ram

5. Fan Drive Shaft

6. Mounting Bolts

7. Ram Pins

8. Metal

9. Retainer

10. Fiber

11. Spacer

12. Mounting

13. Bars

14. Belt Guard

15. Hinge Rod

16. Retainer

17. Hair

18. Pins

19. 12V Winch

20. Hinge Washers

21. Nut

22. Washer

23. Bolt

24. Skid Shoe

25. Drive Belt Pulley (Engine)

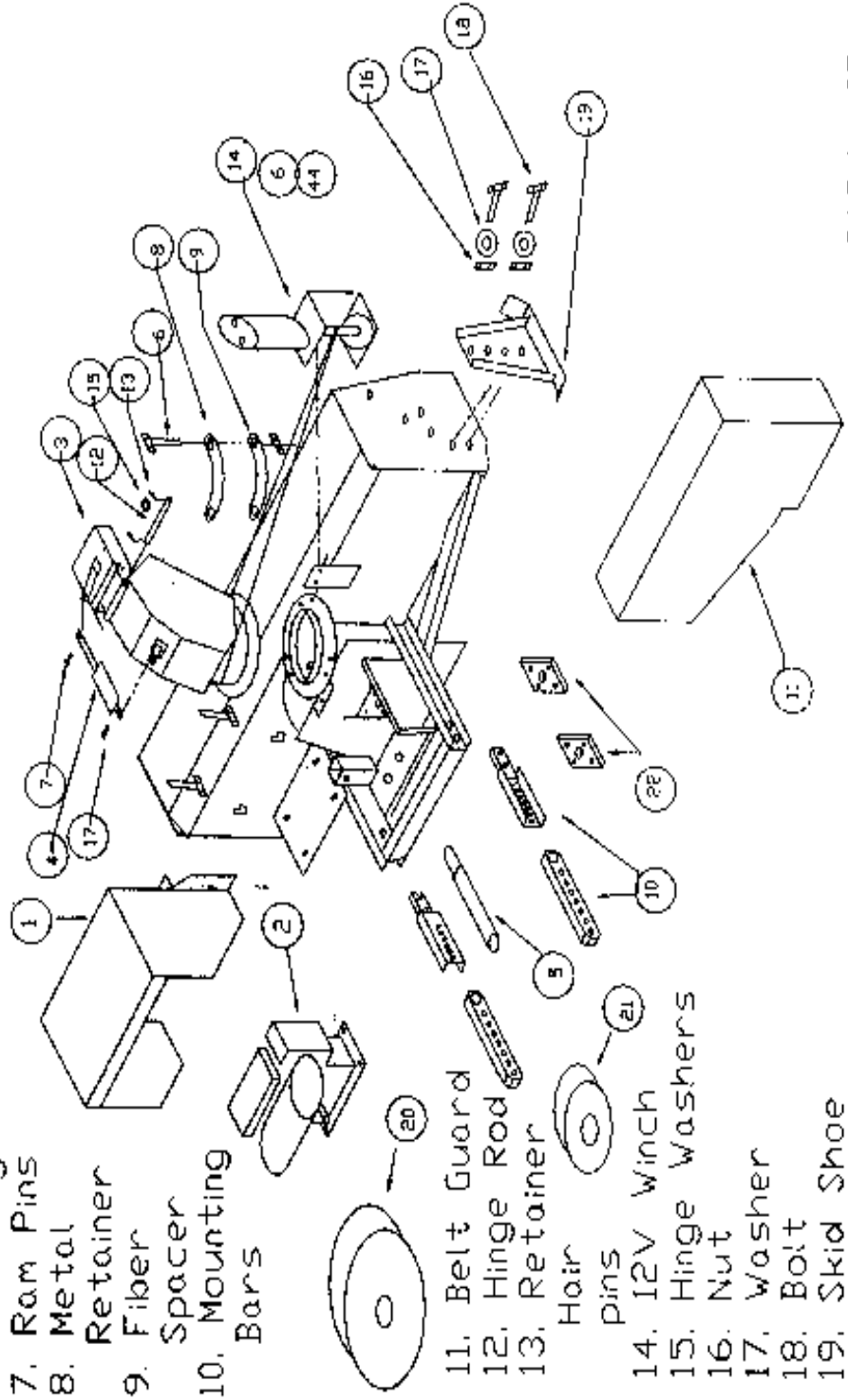

BACK VIEW

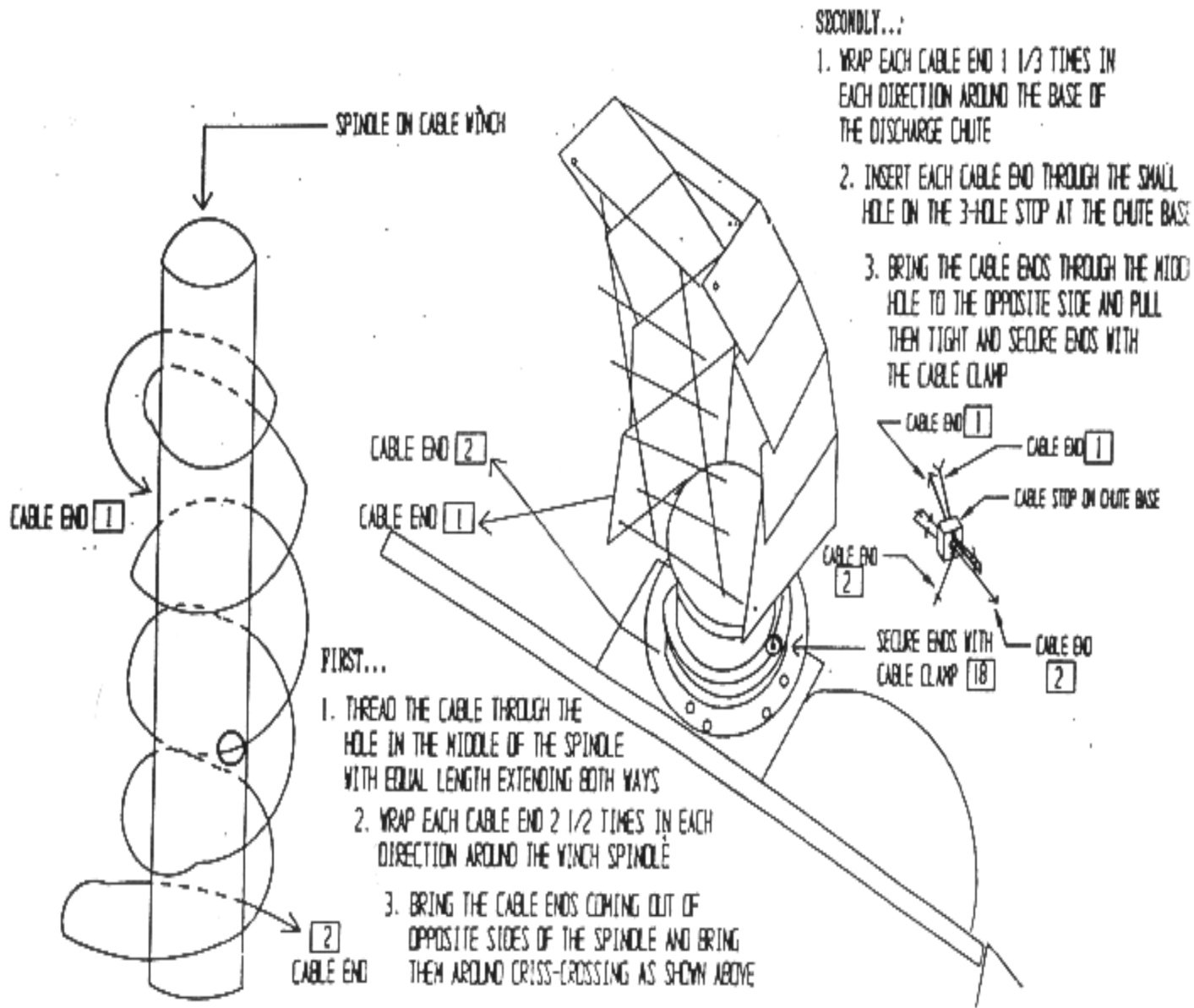

- FIRST...
1. THREAD THE CABLE THROUGH THE HOLE IN THE MIDDLE OF THE SPINDLE WITH EQUAL LENGTH EXTENDING BOTH WAYS
 2. WRAP EACH CABLE END 2 1/2 TIMES IN EACH DIRECTION AROUND THE WINCH SPINDLE
 3. BRING THE CABLE ENDS COMING OUT OF OPPOSITE SIDES OF THE SPINDLE AND BRING THEM AROUND CRISS-CROSSING AS SHOWN ABOVE

- SECONDLY...
1. WRAP EACH CABLE END 1 1/3 TIMES IN EACH DIRECTION AROUND THE BASE OF THE DISCHARGE CHUTE
 2. INSERT EACH CABLE END THROUGH THE SMALL HOLE ON THE 3-HOLE STOP AT THE CHUTE BASE
 3. BRING THE CABLE ENDS THROUGH THE MIDDLE HOLE TO THE OPPOSITE SIDE AND PULL THEM TIGHT AND SECURE ENDS WITH THE CABLE CLAMP

WINCH CABLE INSTALLATION FOR ELECTRIC STACK ROTATION CONTROL